

Vacuum Packers

Mobile Vacuum Packer-40 m³/h

ITEM # _____

MODEL # _____

NAME # _____

SIS # _____

AIA # _____

600045 (EVP50F)

 Mobile Vacuum Packer - 40
 m³/h - 380 V/3/50-60

Short Form Specification

Item No. _____

Floor standing model on wheels. Constructed in 304 AISI stainless steel. Domed transparent Plexiglas lid. Pressure chamber with rounded corners. Digital control panel for programming and storing of up to 9 operating programs (including the external vacuum one). Mechanical "soft air" device allows the controlled re-admission of air into the chamber. Basic display shows the selected program and related settings, including alarm messages if errors are detected by the electronic board. Electronic board detects electronic malfunctions, color and oil level as well as other failures in the vacuum packing process. Safety system protects the machine in case of sealing bar overheating. Sealing bar length 500mm.

APPROVAL: _____

Main Features

- Free-standing appliance mounted on 4 castors.
- Digital control panel allows the selection of up to 9 operating programs to guarantee optimized vacuum pressure and heat seal time for any product and each program: P1 to P8 are composed of 4 adjustable selections (vacuum, extravacuum, gas and sealing) while P9, "external vacuum" is composed by only 2 selections (vacuum and extravacuum).
- To ensure simplicity of use and maximum reliability electronic board detects electronic malfunctions, color and level of oil as well as failures in the vacuum packaging process.
- Safety system protects the machine in case of sealing bar overheat.
- Can be equipped with an adapter (available as optional accessory), allowing the vacuum process to take place in external containers or appliances by connecting the external container's pipe to the air sucking valve.
- Digital control panel allows programming and storing of up to 9 operating programs for a better vacuum pressure and heat seal times.
- Microprocessor automatically controls the exact percentage of negative pressure needed for all the air to be removed.
- Warning light to indicate malfunctioning in the vacuum packing process.
- "Soft air" device allowing to control the re-admission of air into the chamber.

Construction

- Entirely constructed in 304 AISI stainless steel.
- Unit to have a domed transparent Plexiglass lid.
- Pressure chamber with rounded corners.

Optional Accessories

- Inclined filling table to vacuum PNC 650011 pack liquids for 40 m³/h vacuum packers

Front

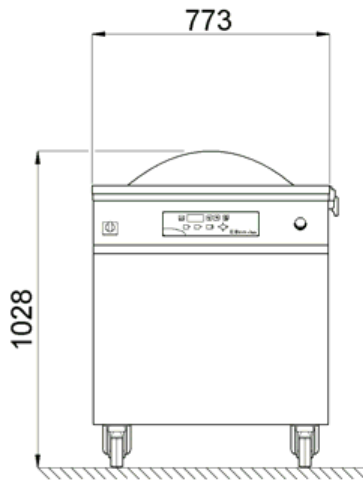

Side

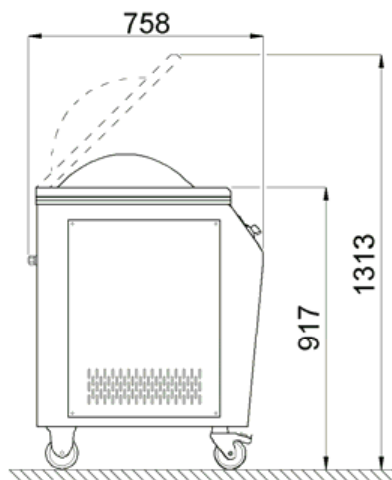

EI = Electrical inlet (power)

Other

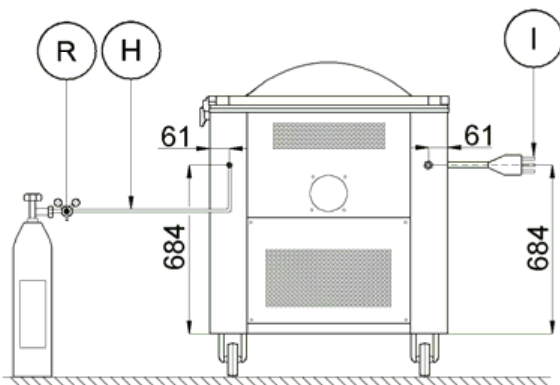

Electric

Supply voltage:

600045 (EVP50F)

380 V/3 ph/50 Hz

Total Watts:

1.5 kW

Key Information:

Pump:	40 m ³ /h
External dimensions, Width:	765 mm
External dimensions, Depth:	760 mm
External dimensions, Height:	1030 mm
Chamber width:	663 mm
Chamber depth:	518 mm
Chamber height:	241 mm
Sealing bar length:	500 mm
Net weight (kg):	185